

Cool solutions to thermal problems.

Rocky
Research

COMMERCIAL | INDUSTRIAL | DEFENSE

SAS1500
SAS2500

Key Features

- Photoelectric or Ionization Sensors
- Designed to Withstand Harsh Environments
- Rugged Housing
- No Tools Required for Head Replacement
- Head Retention without Air Flow Disturbance.
- Addressable Communication
- Magnetic Test Feature activations
- 360 Degree Smoke Entry
- Insect Screens

Rocky Research Smoke Sensor Assembly



Utilizing commercial-off-the-shelf, state-of-the-art components, Rocky Research has designed Smoke Sensor Assemblies to provide high reliability fire and smoke detection for industrial and military environments. Rocky Research has designed and tested this system along with the Rocky Research Advanced Fire and Smoke System to withstand harsh environments encountered aboard Navy ships – high shock, vibration, EMI, and temperature levels.

The Rocky Research Photoelectric and Ionization Smoke Sensor Assemblies include an aluminum housing and utilize a cable feed-thru design to meet EMI and environmental requirements while providing ease of installation. The housing has multiple entry points for wiring to allow flexibility at installation. The sensor assemblies incorporate a *patent pending* retaining system that provides durability in the harshest environments including the most severe shock requirements. The retaining system allows for head replacement without the use of tools. The housing offers multiple mounting points for overhead and bulkhead installation in any orientation.

The Photoelectric Sensor Assembly **SAS1500** and the Ionization Sensor Assembly **SAS2500** are built with the latest commercial-off-the shelf sensing devices while inherently designed for ease of installation. Both of these smoke sensing assemblies have 360 degree smoke entry for optimum response and built-in insect screens. The sensor bases are uniquely programmable for ease of monitoring specific locations.

System Specifications

Technology:	Addressable Fire Detection and Control Electronics
Device:	SAS1500 Photoelectric Sensor The photoelectric sensor utilizes pulsed infrared LED light source and a silicon photodiode Receiver to provide consistent and accurate low power smoke sensing
Device:	SAS2500 Ionization Sensor The uses a single radioactive source with an outer sampling ionization chamber and an Inner reference ionization chamber to provide stable operation under fluctuations in environment such as temperature and humidity.
Power:	24VDC
Communication:	IDNet™

Physical Specifications

Form Factor:	Overhead or Wall-Mount Installation
Dimensions:	Photoelectric and Ionization Sensor Assembly – 3.93”H x 6.27” Diameter
Weight:	1.5 lbs.
Mounting:	5 inches between mounting holes

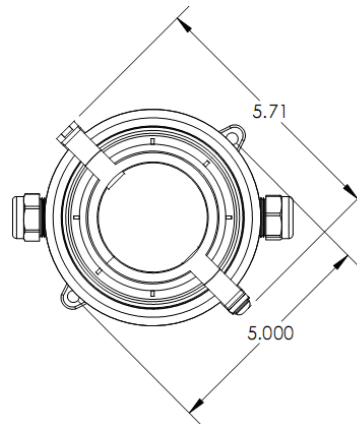
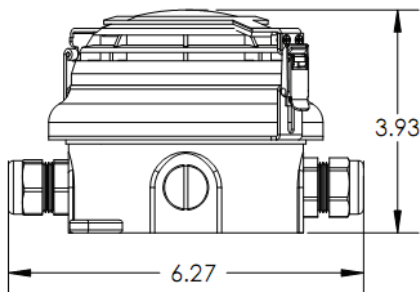

Environmental Specifications – Designed to Meet

Shock:	MIL-STD-901D, Grade A, Class I, Type A
Vibration:	MIL-STD-167-1A, Certified
EMI:	MIL-STD-461E and F, Certified
Temperature:	0° to 65° C
Enclosure Protection:	MIL-E-2036, Drip-Proof up to 15 degrees